

Performance List		
Nominal Diameter	48"	
Nominal Pressure	600 LB	
Test Pressure	Strength Test	15
	Sealing Test	11 Mpa
	Air Sealing	0.6
Working Temperature	Between -	°C
Medium	Water, Oil,	

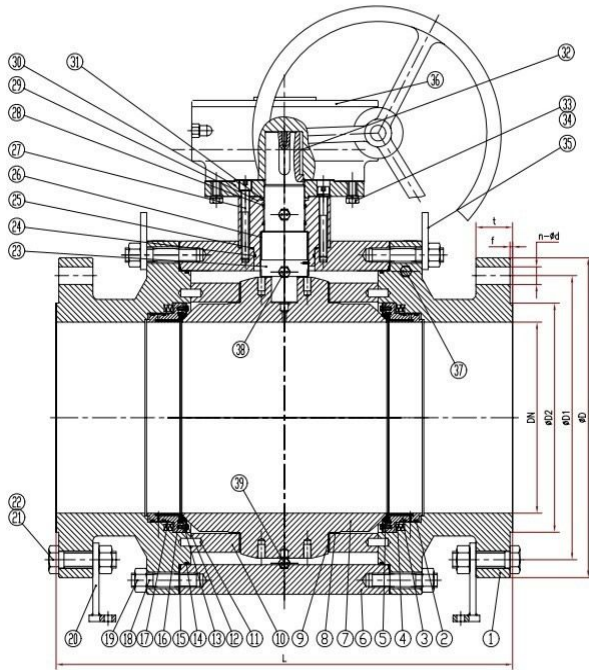

39	Drain Valve	CS
38	Vent Valve	CS
37	Sealant Injection Valve	CS
36	Turbine	Part
35	Lug	Q235-A
34	Spring Gasket	65 Mn
33	All Thread Hexagonal Bolt	ASTM A193 B7
32	Common Flat Key	35
31	Packing	Flexible Graphite
30	Connection Panel	ASTM A350 LF2
29	Upper Valve Bonnet	A350 LF2
28	O-ring	Fluorine Rubber
27	Inner Hexagonal Screw	Steel Grade 8.8
26	Composite Bearing	SF-1
25	Metal Winding Pad	304+Graphite
24	O-ring	Fluorine Rubber
23	Upper Valve Stem	ASTM A276 420
22	Nut	Steel
21	All Thread Hexagonal Bolt	Steel Grade 4.8
20	Tripod	Q235-A
19	Nut	4
18	Bolt	L7
17	Graphene Tape	Flexible Graphite
16	O-ring	Fluorine Rubber
15	Metal Winding Pad	304+Graphite
14	O-ring	Fluorine Rubber
13	Sealing Pressure Plate	A350 LF2
12	Bolt	A193 B7
11	Cylinder Pin	SS304
10	Support Board	A350 LF2
9	Composite Bearing	SF-1
8	Plane Composite Bearing	SF-1
7	Ball	ASTM A350 LF2
6	Body Mid Section	ASTM A350 LF2
5	Sealing Ring	Nylon
4	Spring	17-7PH
3	Valve Seat	ASTM A350 LF2
2	O-ring	Fluorine Rubber
1	Left Right Part	ASTM A350 LF2

48"	600	1020	2400	1403	1282.7	1168	174	6.4	28 x Ø 66.5
Size	Class	DN	L	D	D1	D2	t	f	n- Ød