

300kw marine diesel generator



General features:

- Coupled with Cummins diesel engine and LEROY-SOMER alternator
- 24V DC start motor
- Brushless, Self-excited, IP23, insulation class H alternator

Genset Main Technical Data

3-PH, 60Hz@1800RPM, 440/240V (Also Can Be Made According To Customers' Special Requirements)

Voltage	HZ	Phase	PF (COS ϕ)	Output (KW)
440/240V	60	3	0.8	300

Criterion

- GB/T13032-1991
- ISO9001:2008 Quality Control System
- CCS ,BV,DNV,ABS,GL,RRR approved
- EIAPP II certificate



Diesel Engine Technical Data

Number of Cylinders	6 cylinders in line
Cycle	4 stroke
Aspiration	Turbocharged and aftercooled
Bore×Stroke	159 x159 mm
Displacement	19.0 L
Compression ratio	13.9:1
Prime Power/Speed	425 KW/1800 rpm
Speed Governor	electrical
Cooling System	By heat exchanger
Fuel Consumption at 100% Load	197 g/kw.h
Starter Motor	DC24V,

Alternator Technical Data

Prime power	300KW
Frequency/speed	60HZ/1800rpm
Exciter type	Brushless, Self-excited
Power factor	0.8
Insulation Grade	H
Protection Grade	IP23
Phase / wire	3 phase 3 wires

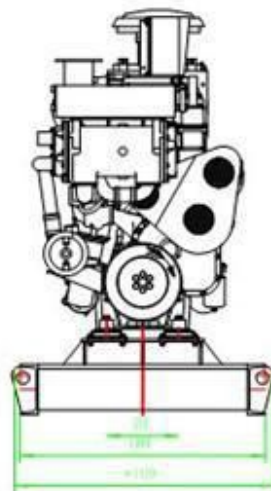
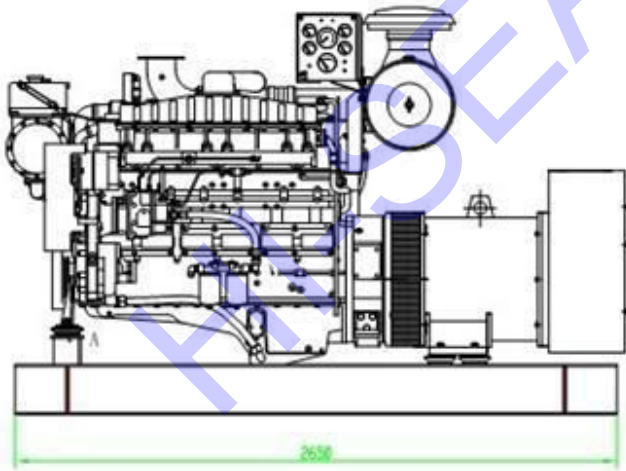

Chongqing Hi-Sea Marine Equipment Import&Export Co.,Ltd.

Address: 20-5,General Chamber of Commerce Building, No.2 Hongjin Street, Yubei District, Chongqing, China

Email: machine@hiseamarine.com mitang0708@foxmail.com **Skype:** cncqtang **QQ:** 2278612160

TEL: +86-23-67032301 **FAX:** +86-23-67955123 **Mobile:** +86-18108354610 **Post Code:**401147

Website: www.hiseamarine.com www.chinahisea.com