

## 400kw marine diesel generator



### General features:

- Coupled with CUMMINS diesel engine and STAMFORD alternator
- 24V DC start motor
- Brushless, Self-excited, IP23, insulation class H alternator

### Genset Main Technical Data

3-PH, 50Hz@1500RPM, 380V(Also Can Be Made According To Customers' Special Requirements)

Voltage	HZ	Phase	PF (COS $\phi$ )	Output (KW)
380V	50	3	0.8	400

### Criterion

- GB/T13032-1991
- ISO9001:2008 Quality Control System
- CCS,BV,ABS,DNV,RRR approved
- Tier II



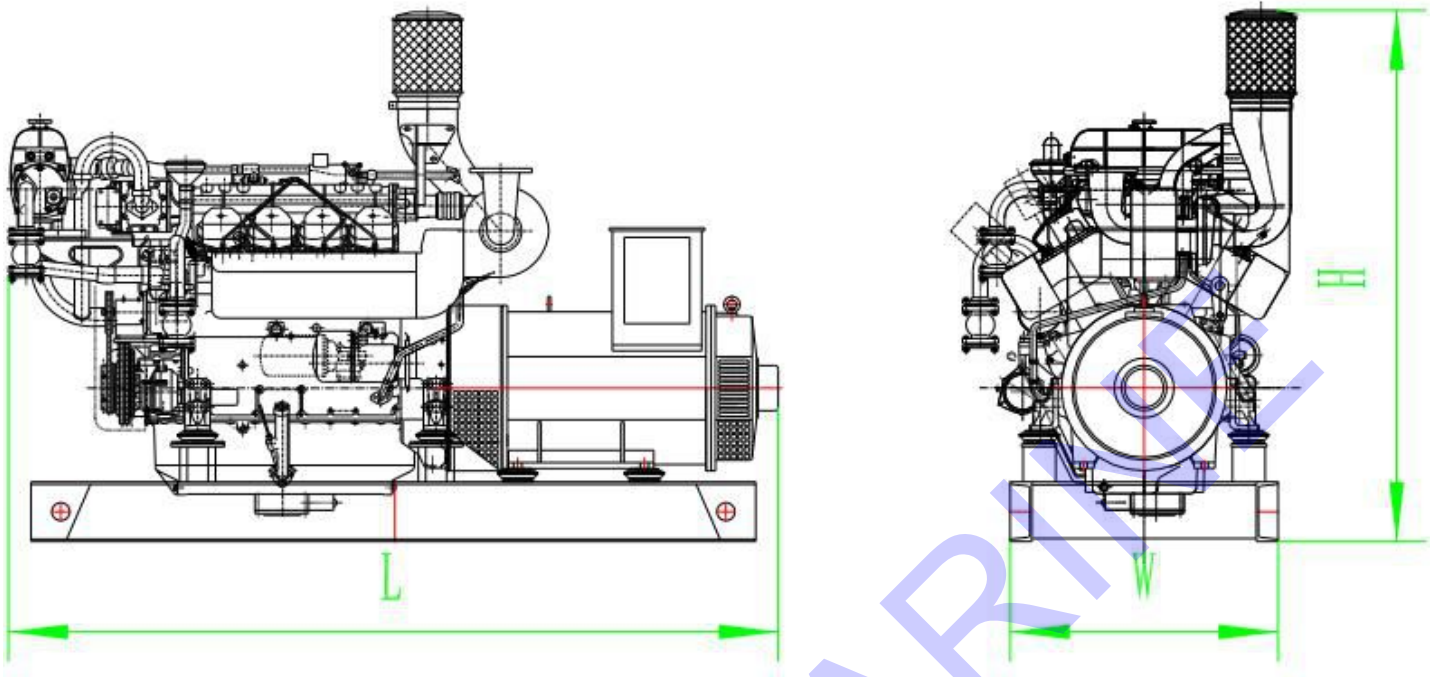

### Diesel Engine Technical Data

Number of Cylinders	6 cylinders in line
Cycle	4 stroke
Aspiration	Turbocharged and aftercooled
Bore×Stroke	159 x159 mm
Displacement	19.0 L
Compression ratio	13.9:1
Prime Power/Speed	448KW/1500rpm
Speed Governor	electrical
Cooling System	By heat exchanger
Fuel Consumption at 100% Load	204 g/kw.h
Starter Motor	DC24V,

### Alternator Technical Data

Prime power	440KW
Frequency/speed	50HZ
Exciter type	Brushless, Self-excited
Power factor	0.8
Insulation Grade	H
Protection Grade	IP23
Phase / wire	3 phase 3 wires

## Control System

Model	KCM II G
<ul style="list-style-type: none"> <li>* engine start/stop</li> <li>* engine coolant temperature</li> <li>* oil pressure and temperature</li> <li>* tachometer</li> <li>* coolant temperature alarm</li> <li>* oil pressure alarm</li> <li>* battery charging indicator</li> <li>* generator to be protection from overload and overheat</li> </ul>	



400kw marine diesel generator in factory

### Chongqing Hi-Sea Marine Equipment Import&Export Co.,Ltd.

**Address:** 20-5,General Chamber of Commerce Building, No.2 Hongjin Street, Yubei District, Chongqing, China

**Email:** machine@hiseamarine.com mitang0708@foxmail.com **Skype:** cncqtang **QQ:** 2278612160

**TEL:** +86-23-67032301 **FAX:** +86-23-67955123 **Mobile:** +86-18108354610 **Post Code:**401147

**Website:** www.hiseamarine.com www.chinahisea.com