

1700KW MWM-HND Marine Generator



General features:

1. Coupled with HND-MWM diesel engine and Siemens alternator
2. Air Star
3. Brushless, Self-excited, IP44, insulation class F alternator

Main Technical Data

3-PH, 60Hz@1800RPM, 690V (Also Can Be Made According To Customers' Special Requirements)

Voltage	HZ	Phase	PF (COS ϕ)	Output (KW)
690V	60	3	0.8	1700

Criterion

1. GB/T13032-1991
2. ISO9001:2008 Quality Control System
3. CCS,BV,ABS,DNV,RRR approved
4. Tier II



Dimension

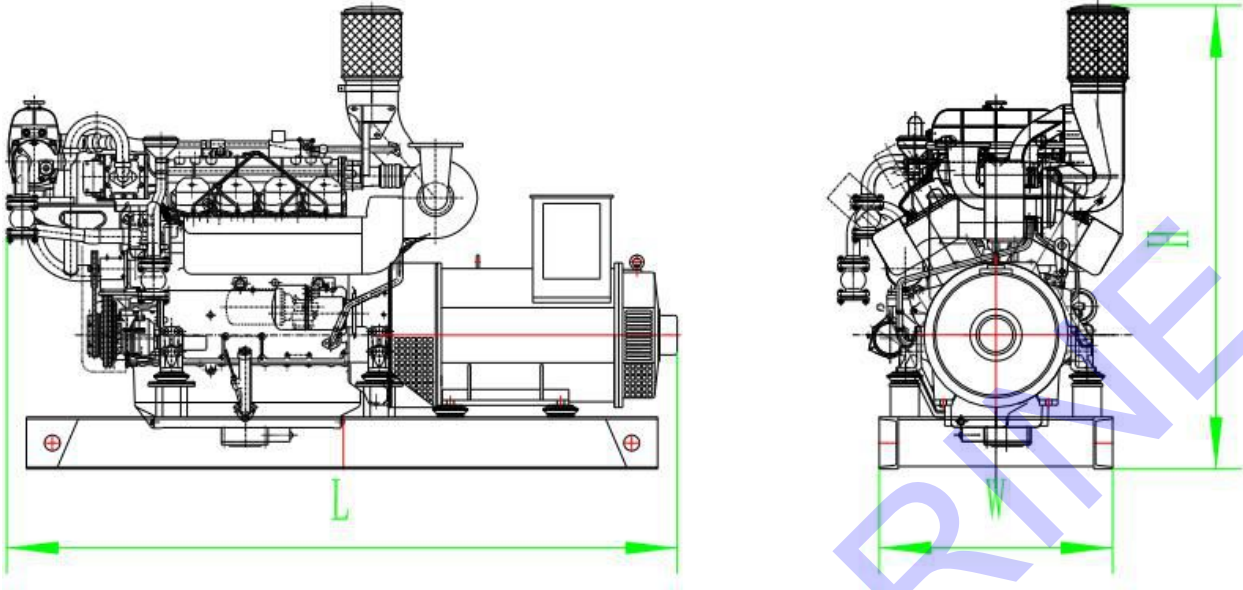

HND-MWM Diesel Engine

Technical Data

Engine Model	TBD620V16
Number of Cylinders	16 cylinders in V
Cycle	4 stroke
Aspiration	Turbocharged and aftercooled
Bore×Stroke	170 x195 mm
Displacement	70.88L
Compression ratio	13.5:1
Prime Power/Speed	1819KW/1800rpm
Speed Governor	electrical
Cooling System	By heat exchanger
Fuel Consumption at 100% Load	193 g/kw.h
Starter Motor	DC24V,

Siemens Alternator

Technical Data

Alternator Model	1FJ2 564-4
Prime power	1700KW
Frequency/speed	60HZ/1800rpm
Exciter type	Brushless, Self-excited
Power factor	0.8
Insulation Grade	F
Protection Grade	IP44
Phase / wire	3 phase 3 wires

Documents

<p>a. Alternator Operation and maintenance manual ABS certificate</p>	<p>1PC 1PC</p>
<p>b. Engine Operation and maintenance manual ABS certificate EIAPP II certificate</p>	<p>1PC 1PC 1PC</p>
<p>c. Generator Overall drawings of the set ELECTRINIC SYSTEM DRAWING Bench test Packing list</p>	<p>1PC 1PC 1PC 1PC</p>
<p>d. Control panel ABS certificate Operation and maintenance manual</p>	<p>1PC 1PC</p>

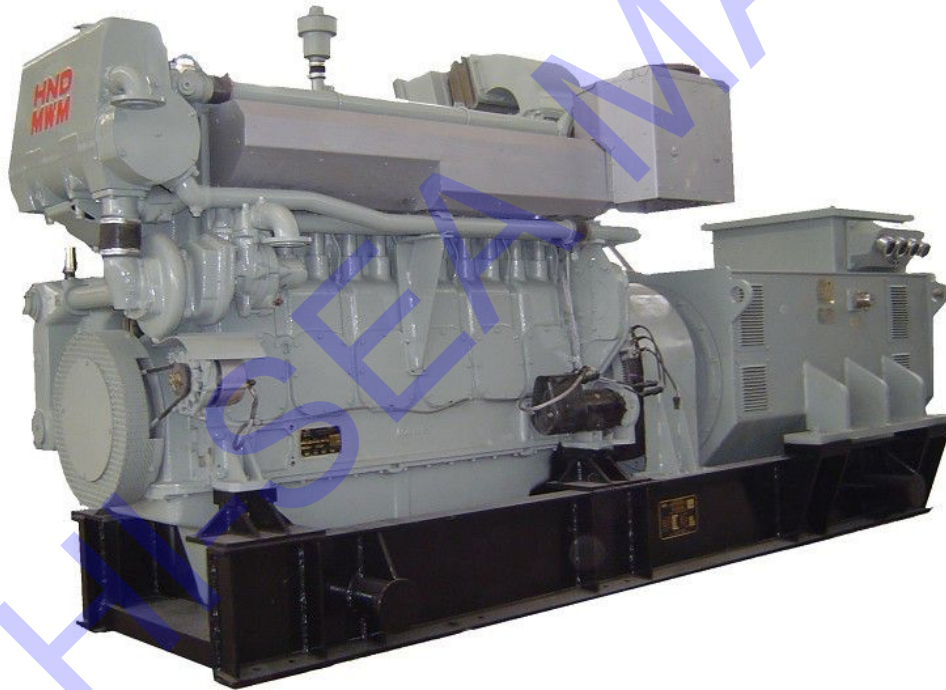

1700kw MWM marine generator

Chongqing Hi-Sea Marine Equipment Import&Export Co.,Ltd.

Address: 20-5,General Chamber of Commerce Building, No.2 Hongjin Street, Yubei District, Chongqing, China

Email: machine@hiseamarine.com mitang0708@foxmail.com **Skype:** cncqtang **QQ:** 2278612160

TEL: +86-23-67032301 **FAX:**+86-23-67955123 **Mobile:** +86-18108354610 **Post Code:**401147

Website: www.hiseamarine.com www.chinahisea.com