

Technique Requirements

- 1.Grinding the surface defects by wheel.
- 2.Allowance is $\pm 3\%$,exclude special mark,unit ismm;
- 3.Material of castings(ZG200-400), Forgings(U2).
- 4.Turn flexibly between the Anchor head& shank shackle
- 5.Sholing blast for the product surface.

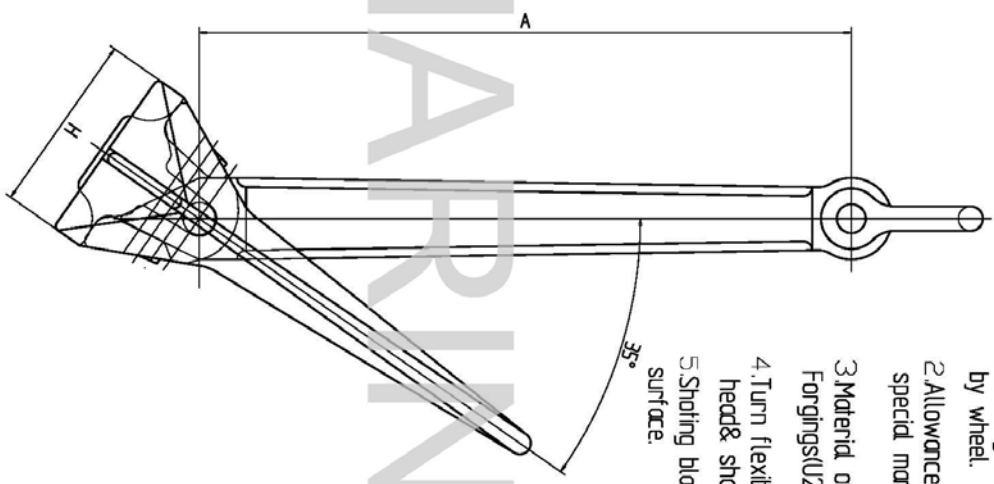
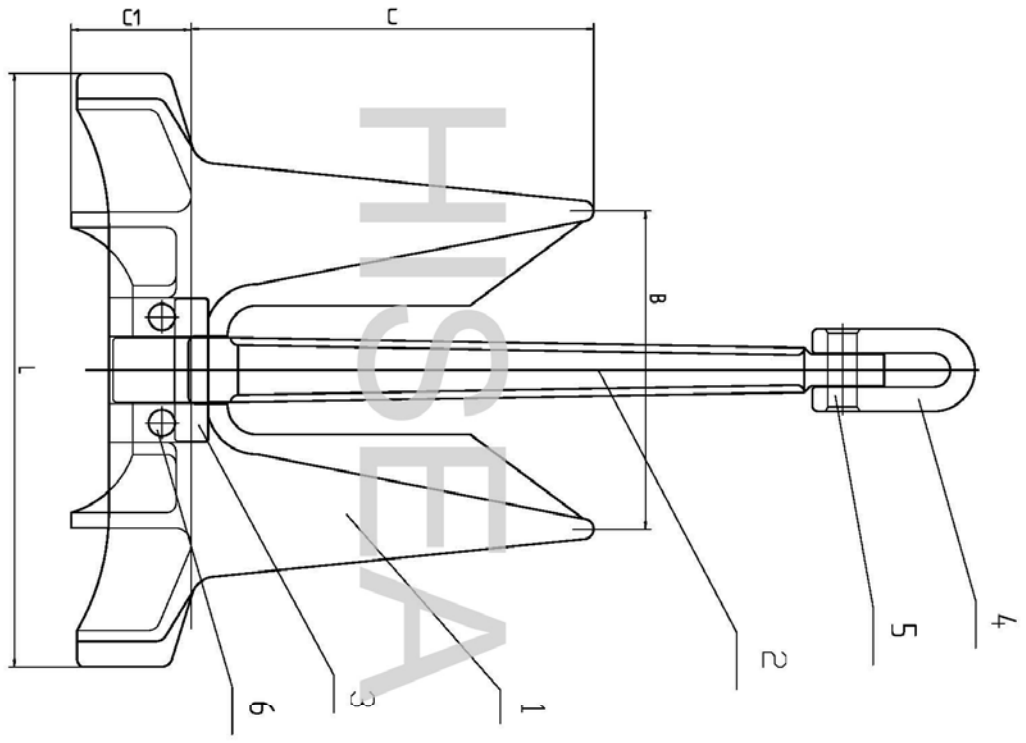

6	TRANSVERSE PIN	2	U ₂					
5	SHACKLE PIN	1	U ₂					
4	SHACKLE	1	ZG200-400					
3	HEAD PIN	1	U ₂					
2	SHANK	1	ZG200-400					
1	FLUKE	1	ZG200-400					

Work Num	Amend No	Signed	Date
Design			
Check			
Reviewed			
Approved			

ASS OF AC-14 H.H.P ANCHOR

DRAWING NO.

Drawing No. WT(KG) Scale

Total 2 Pages Pg 1

CHONGQING HI-SEA MARINE EQUIPMENT IMPORT&EXPORT CO.,LTD

HI-SEA MARINE

NOMINAL WEIGHT (kg)	A	L	H	C	C1	B
50	590	529	164	359	107	283
75	677	605	188	411	122	324
90	718	643	199	437	130	344
100	745	666	207	452	135	357
135	821	737	228	500	143	394
180	904	811	251	550	157	434
225	974	874	270	593	169	468
340	1109	995	307	675	192	533
460	1227	1101	340	747	212	590
544	1317	1172	363	795	237	627
675	1398	1254	387	851	242	672
750	1483	1304	404	885	264	698
855	1520	1363	423	925	267	729
910	1540	1385	427	938	270	740
1000	1590	1425	440	968	275	764
1140	1660	1490	460	1011	287	798
1360	1761	1580	488	1072	305	846
1440	1795	1610	497	1093	311	862
1590	1855	1665	514	1130	321	892
1820	1940	1741	538	1182	336	933
2040	2016	1809	559	1227	349	969
2270	2089	1874	579	1272	362	1004
2720	2218	1991	615	1351	384	1066
3040	2302	2066	638	1402	399	1107
3240	2352	2110	652	1432	407	1130
3445	2400	2154	665	1462	415	1154
3670	2451	2200	680	1493	424	1178
3940	2510	2252	696	1529	434	1207
4210	2566	2303	711	1563	444	1234
4500	2624	2355	727	1598	454	1261
4840	2688	2412	745	1637	465	1292
5175	2749	2467	762	1674	476	1321